

TNF

CONTATTO TAPPARELLE PER MONTAGGIO A VISTA

SURFACE MOUNTING ROLLER-UP SHUTTER CONTACT



DESCRIZIONE

Contatto tapparelle contro strappi, tagli del cordino e contro sollevamento tapparelle e saracinesche. Contenitore in plastica ABS. Montaggio a vista.

CARATTERISTICHE TECNICHE

| | |
|---------------------------|----------------------|
| Materiale: | ABS, grigio |
| Forma: | rettangolare |
| Dimensioni: | mm 84x95x16 |
| Dimensioni guida cordino: | mm 12Ø x 20 |
| Utilizzo / Montaggio: | a vista |
| Collegamenti elettrici: | 2 fili |
| Contatti elettrici: | NC |
| Tensione massima: | 100Vcc |
| Corrente massima: | 1A a 100Vcc |
| Scheda lettura impulsi: | ST e STP non inclusa |
| Tamper: | no |
| Livello di protezione: | 1 |
| Lunghezza del cavo: | 12cm |
| Temperatura operativa: | -10°C / +50°C |
| Classe ambientale: | II |
| Grado di protezione: | IP20 |
| Conformità: | EN50131-2-6 |
| Fabbricato in: | Italia, da FDP |

DISEGNO TECNICO

Disegno tecnico e quote in millimetri. Disegno non in scala.

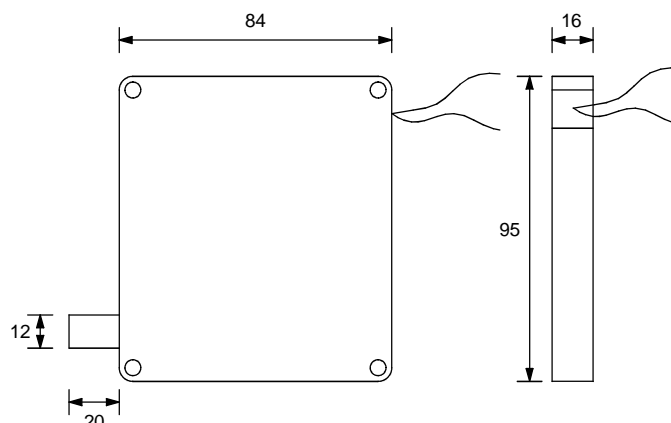

DESCRIPTION

Roller-up shutter contact against the rip and cut of string and against the moving of roller-up shutter and overhead doors. Box in ABS plastic. Surface mounting.

TECHNICAL FEATURES

| | |
|-----------------------|----------------------|
| Material: | ABS, grey |
| Shape: | rectangular |
| Size: | mm 84x95x16 |
| String string guide: | mm 12Ø x 20 |
| Use / Fixing: | surface mounting |
| Electric connection: | 2 wires |
| Electric contacts: | NC |
| Voltage (maximum): | 100Vdc |
| Current (maximum): | 1A at 100Vdc |
| Pulses reading board: | ST, STP not included |
| Tamper: | no |
| Protection level: | 1 |
| Cable length: | 60cm |
| Working temperature: | -10°C / +50°C |
| Environment class: | II |
| Protection grade: | IP20 |
| Conformity: | EN50131-2-6 |
| Made in: | Italy, by FDP |

TECHNICAL DRAW

Technical draw and size in millimeters. Draw not in scale.